

presek A-A
R 1:25

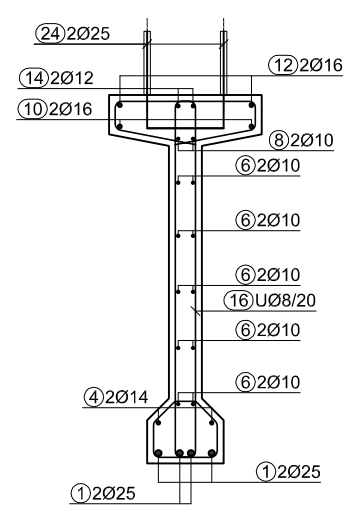

presek B-B
R 1:25

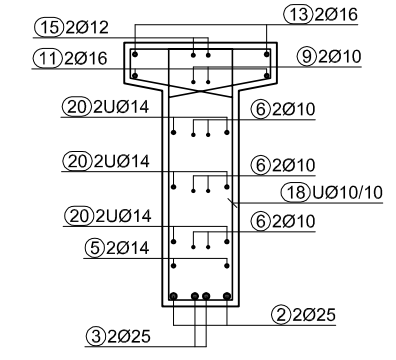

presek C-C
R 1:25

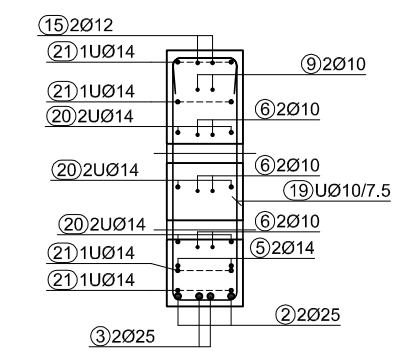

Užad za prednaprezanje St1670/1860 0,5" (12,5mm)
 sila prednaprezanja 120 kN/1uže
 Beton pri opuštanju užadi MB45
 Beton u eksploataciji MB60

V= 8.756 m³ m= 21.89 t
 B500B, St 1670/1860
 C 50/60, a=2.5 cm
PLAN ARMATURE MONTAŽNIH AB GLAVNIH NOSAČA
 POS GN1, GN1.1, GN1.2

3 kom / pcs

Objekat / Object : Proširenje objekta br.2 spratnosti P+0	
Sadržaj / Content : Plan armature AB montažnih glavnih nosača POS GN1, GN1.1, GN1.2	
Projekat / Project : PZI	Datum / Date : 29.11.2017.
Razmera / Scale : 1:60	Oznaka lista / No sheet : REV : 1